

# Design “di contorno”

Battiscopa in legno  
*Wooden baseboards*



# Design “di contorno”

Battiscopa in legno  
*Wooden baseboards*

Il Battiscopa diventa elemento di Design, capace di caratterizzare con personalità l'ambiente.

Gli spazi si completano e si arricchiscono di un contorno capace di raccontare stili, tendenze e modi di essere. San Giuseppe rappresenta, in questo, originalità ed evoluzione.

---

*The skirting board becomes an element of Design capable of characterizing the environment with personality.*

*The spaces are completed and enriched with a contour capable of telling styles, trends and ways of being. Here San Giuseppe represents originality and evolution.*

# la Nostra Storia

## Our History

Amore e passione per il proprio lavoro si uniscono ad una consolidata esperienza per garantire massima qualità all'intero ciclo produttivo.

*Love and passion for our own work are combined with an extensive experience to guarantee the highest quality to the entire production cycle.*

Il filo conduttore di San Giuseppe è la scrupolosa e costante attenzione alla qualità in tutte le fasi. L'accurata selezione delle migliori materie prime, lavorate con le più moderne linee produttive, garantisce collezioni che esprimono qualità dal sapore artigianale.

since  
1968

*The common thread of San Giuseppe is the scrupulous and constant attention to quality in all phases. The careful selection of the best raw materials, worked with the most modern production lines, guarantees collections that express quality with an artisan flavor.*

## Sagome su misura Custom profiles

L'ampia gamma di battiscopa di Nostra produzione accontenta sia il gusto dalle linee più classiche sia quello caratterizzato da un sapore più contemporaneo e minimale. La competenza e la flessibilità di San Giuseppe permettono, inoltre, di realizzare profili con sagome personalizzate come da precise indicazioni del cliente. Completano la nostra gamma le aste da parati, i coprifili per porte, i fermavetro, i listelli e i tondi in legno massiccio.

*The wide range of baseboards of our production satisfies both the taste with the most classic lines and the one characterized by a more contemporary and minimal flavour. The expertise and flexibility of San Giuseppe also allow the creation of profiles with customized shapes as per the customer's precise indications. Completing our range are the profiles for wall paper, faced doors profile, pane holders, fillets, rods and handrails.*

## Verniciature Painting

Il ciclo di verniciatura avviene internamente ai nostri stabilimenti con tecniche e tecnologie costantemente aggiornate. La preparazione dei tecnici di reparto garantisce costanza e continuità nelle tinte dei vari prodotti essendo ogni singola finitura regolata da rigide ricette amministrare da un know how sempre più ampio e consolidato.

*The painting cycle takes place internally with constantly updated techniques and technologies. The preparation of the department technicians ensures consistency and continuity in the colours of the various products being each single finish regulated by rigid recipes administered by an increasingly broad and consolidated know-how.*



## i Nostri Plus Our Features

## Consegne e magazzino Deliveries and warehouse

San Giuseppe evade in tempi molto brevi gli ordini acquisiti in quanto tutti i prodotti presenti nel catalogo sono disponibili nell'ampio magazzino puntando quindi ad una sempre più completa soddisfazione del cliente.

*San Giuseppe quickly fulfills the orders acquired as all the products in the catalogue are available in the large warehouse, thus aiming at a complete customer satisfaction.*

## infinite Finiture

### Endless Finishes

Infinite possibilità di colore. Ci contraddistingue la flessibilità nelle colorazioni del prodotto desiderato. Non solo attraverso indicazione di RAL o NCS ma, anche attraverso un semplice campione di riferimento tinta, siamo in grado di realizzare gradazioni mirate alla specifica esigenza del cliente e del suo stile.

*Endless possibility of colour. One of our strengths is the flexibility on colouring the desired product. Not only through the use of RAL or NCS indexes, but also working with a sample as reference, we are able to realize gradations aimed at the specific needs and style of our clients.*

# Battiscopa in legno

*Wooden Baseboards*

La lavorazione e l'impiego sapiente della materia prima per ritrovare il concetto di eleganza declinata allo spazio, sia in chiave classica che contemporanea.

*The processing and the skilful use of raw materials to meet the concept of elegance declined in space, both in a classic and contemporary way.*





**Impiallacciati becco di civetta**  
*Owl beak veneered wood*

p.10

Il bordo superiore arrotondato racconta un'estetica elegante e sofisticata.  
*The rounded upper edge tells of an elegant and sophisticated aesthetic.*

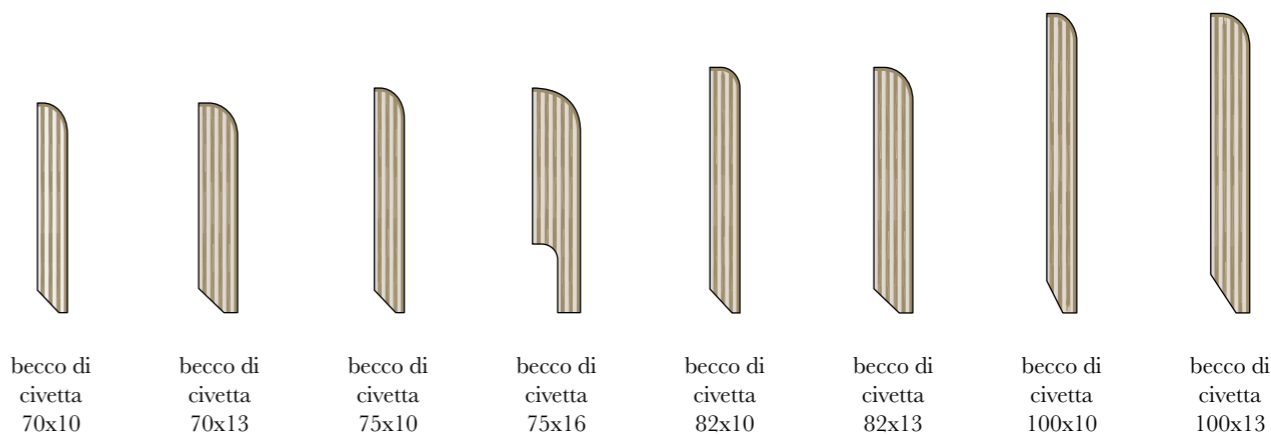

**Massicci**  
*Hardwood*

p.36

Molteplicità di forme, un unico e nobile materiale declinabile ad ogni stile.  
*Multiplicity of shapes, a unique and noble material that can be declined to any style.*

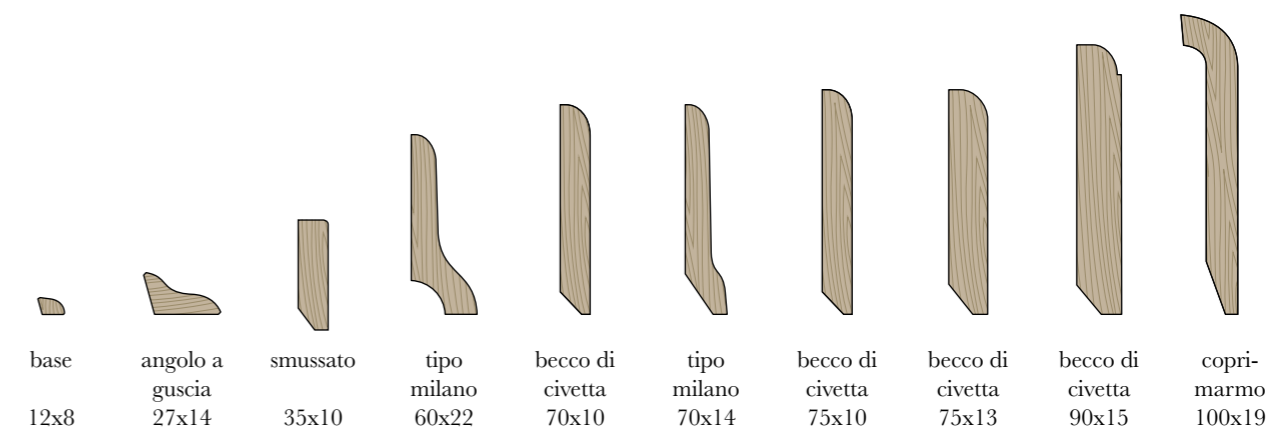

**Impiallacciati smussati**  
*Beveled veneered wood*

p.18

Forme che si adattano a qualsiasi tipologia di spazio esaltandone la personalità.  
*Forms that fit to any type of space, enhancing its personality.*

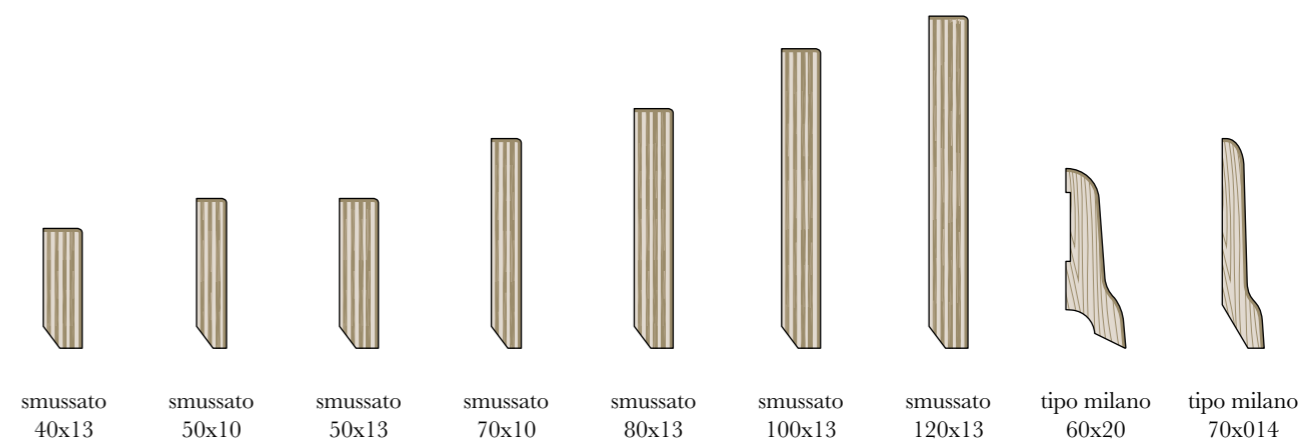

**Massicci sagomati**  
*Shaped hardwood*

p.26

Elementi dalla forte connotazione estetica, a completamento del percorso di arredo.  
*Elements with a strong aesthetic connotation, to complete the furnishing path.*

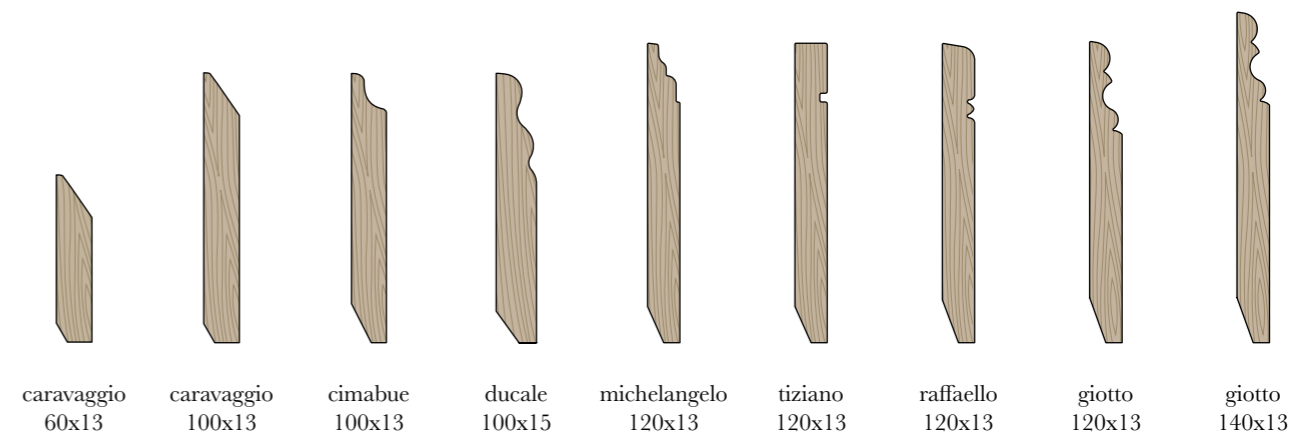

# Becco di Civetta

*Owl Beak*

70x10mm



DETTAGLIO DI GIUNZIONE AD ANGOLO

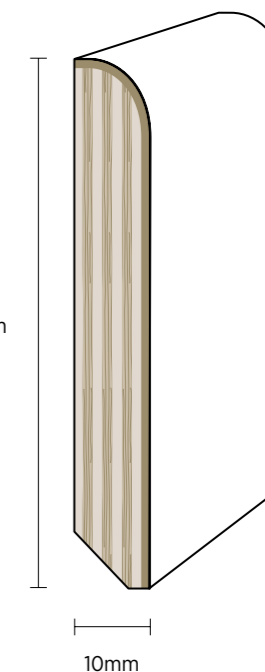

Becco di Civetta



### Dipingere il battiscopa

della stessa finitura a parete è un ottimo espediente per evitare di esagerare con i colori e creare uno sfondo omogeneo.

### To paint the baseboard

with the same wall finish is an excellent way to avoid exaggerating with colours and to create a nice continuity.

## Essenze e Finiture / Essence and Finishes

**ROVERE**  
OAK



**Grezzo**  
*Raw*



**Trasparente verniciato**  
*Transparent varnished*

**TANGANICA**  
TANGANICA



**Grezzo**  
*Raw*



**Tonalità mogano verniciato**  
*Mahogany-coloured varnished*



**Tonalità noce chiaro verniciato**  
*Light walnut-coloured varnished*



**Tonalità noce medio verniciato**  
*Medium walnut-coloured varnished*

## Laccati / Lacquered

**TANGANICA**  
TANGANICA

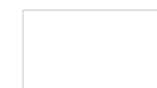

**Laccato bianco traffico RAL 9016**  
*Traffic-white lacquered RAL 9016*



**Laccato grigio alluminio RAL 9006**  
*Grey aluminium lacquered RAL 9006*

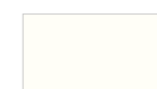

**Laccato bianco puro RAL 9010**  
*Pure white lacquered RAL 9010*



**Laccato grigio platino RAL 7036**  
*Grey platinum lacquered RAL 7036*

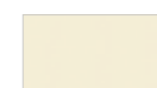

**Laccato bianco perla RAL 1013**  
*Oyster white lacquered RAL 1013*



**Laccato nero**  
*Black lacquered*

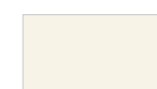

**Laccato bianco crema RAL 9001**  
*Cream white lacquered RAL 9001*



**RAL / NCS e colorazioni su richiesta**  
*RAL / NCS and colours on customer request*



Anche il battiscopa è un dettaglio in vista, quando pensi al **design di un ambiente** ricordati di guardare anche in basso.

*Also the baseboard is a detail in sight, when you think about the **design of an environment**, remember to look down too.*

**Becco di Civetta**  
82x13mm

# Becco di Civetta

*Owl Beak*  
82x13mm



DETTAGLIO DI GIUNZIONE AD ANGOLO

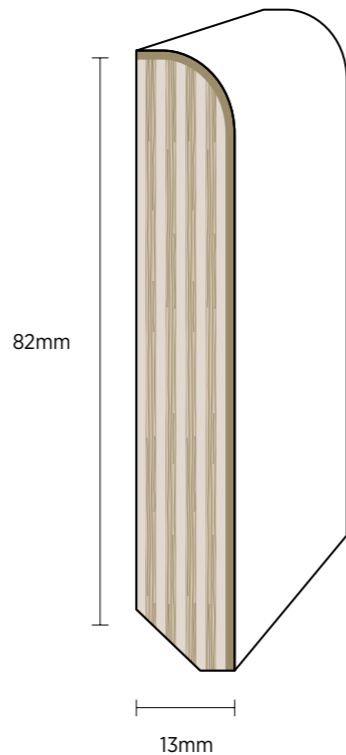

## Essenze e Finiture / Essence and Finishes

	<b>ABETE</b> FIR Grezzo Raw		<b>ACERO AMERICANO</b> AMERICAN MAPLE Trasparente verniciato Transparent varnished
	<b>AFRORMOSIA</b> AFRORMOSIA Trasparente verniciato Transparent varnished		<b>CABREUVA</b> CABREUVA Trasparente verniciato Transparent varnished
	<b>CASTAGNO</b> CHESTNUT Trasparente verniciato Transparent varnished		<b>CILIEGIO</b> CHERRY Trasparente verniciato Transparent varnished
	<b>DOUSSIÉ</b> DOUSSIÉ Trasparente verniciato Transparent varnished		<b>FAGGIO</b> BEECH Trasparente verniciato Transparent varnished
<b>FRASSINO</b> ASH			<b>Trasparente verniciato</b> Transparent varnished
<b>IROKO</b> IROKO			<b>Tinto verniciato</b> Coloured varnished
<b>LARICE</b> LARCH			<b>Trasparente verniciato</b> Transparent varnished

## Essenze e Finiture / Essence and Finishes

	<b>MERBAU</b> MERBAU Trasparente verniciato Transparent varnished		<b>MOGANO</b> MAHOGANY Trasparente verniciato Transparent varnished
	<b>NOCE NAZIONALE</b> ITALIAN WALNUT Trasparente verniciato Transparent varnished		<b>OLMO</b> ELM Trasparente verniciato Transparent varnished
	<b>OLIVO</b> OLIVE TREE Trasparente verniciato Transparent varnished		
<b>ROVERE</b> OAK			<b>Trasparente verniciato</b> Transparent varnished
			<b>Spazzolato verniciato opaco</b> Matte brushed varnished
			<b>Effetto grezzo verniciato</b> Raw effect varnished
			<b>Decapè bianco verniciato</b> Decapè white varnished
			<b>Antico scuro verniciato</b> Old finiture varnished
<b>TANGANICA</b> TANGANICA			<b>Tonalità noce chiaro verniciato</b> Light walnut-coloured varnished
			<b>Naturale verniciato</b> Natural tone varnished
			<b>WENGÉ</b> WENGÉ Trasparente verniciato Transparent varnished
<b>Laccati / Lacquered</b>			
<b>TANGANICA</b> TANGANICA			<b>Laccato grigio alluminio RAL 9006</b> Grey aluminium lacquered RAL 9006
			<b>Laccato grigio platino RAL 7036</b> Grey platinum lacquered RAL 7036
			<b>Laccato nero</b> Black lacquered
			<b>RAL / NCS e colorazioni su richiesta</b> RAL / NCS and colours on customer request





Quando due superfici sono fortemente caratterizzate, una fascia in tinta unita può darti lo **stacco giusto ed armonizzare l'ambiente.**

*When two surfaces are strongly characterized, a plain band can give you the **right break and harmonize the environment.***



## Becco di Civetta

*Owl Beak*

100x13mm



DETTAGLIO DI GIUNZIONE AD ANGOLO

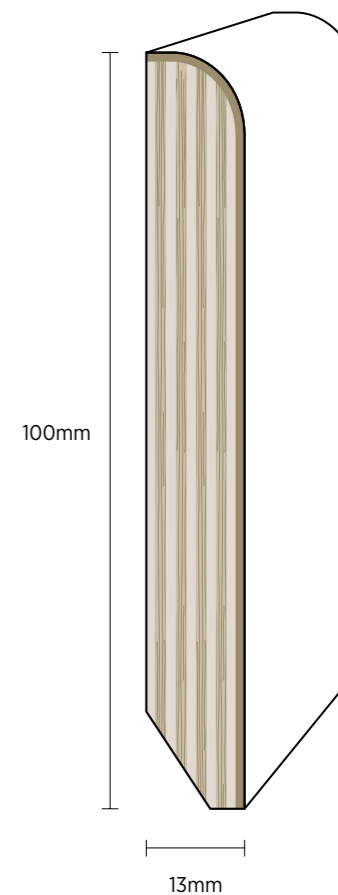

Becco di Civetta

### Essenze e Finiture / Essence and Finishes

**ROVERE**  
OAK



**Grezzo**  
*Raw*



**Trasparente verniciato**  
*Transparent varnished*

**TANGANICA**  
TANGANICA



**Grezzo**  
*Raw*



**Tonalità noce medio verniciato**  
*Medium walnut-coloured varnished*

### Laccati / Lacquered

**TANGANICA**  
TANGANICA

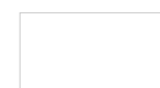

**Laccato bianco traffico RAL 9016**  
*Traffic-white lacquered RAL 9016*



**RAL / NCS e colorazioni su richiesta**  
*RAL / NCS and colours on customer request*

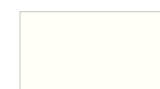

**Laccato bianco puro RAL 9010**  
*Pure white lacquered RAL 9010*

**Asta da parati**  
su disegno del cliente

**Smussato**  
40x13mm

Il contrasto tra un battiscopa  
minimale ed un'asta da parati  
particolare, unite ad una tinta  
pastello, creano un'**atmosfera  
romantica ed attuale.**



*The contrast between a minimal  
skirting and a particular  
wallpaper, combined with a  
pastel color, create a **romantic  
and contemporary atmosphere.***



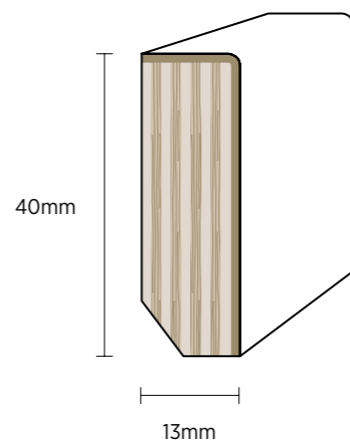

## Smussato

*Beveled*  
40x13mm



DETTAGLIO DI  
GIUNZIONE AD ANGOLO

### Essenze e Finiture / *Essence and Finishes*

<b>ROVERE</b> OAK		<b>Grezzo</b> <i>Raw</i>		<b>Trasparente verniciato</b> <i>Transparent varnished</i>
<b>TANGANICA</b> TANGANIKA		<b>Grezzo</b> <i>Raw</i>		<b>Tonalità noce medio verniciato</b> <i>Medium walnut-coloured varnished</i>

### Laccati / *Lacquered*

<b>TANGANICA</b> TANGANIKA		<b>Laccato bianco traffico RAL 9016</b> <i>Traffic-white lacquered RAL 9016</i>		<b>RAL / NCS e colorazioni su richiesta</b> <i>RAL / NCS and colours on customer request</i>
		<b>Laccato bianco puro RAL 9010</b> <i>Pure white lacquered RAL 9010</i>		





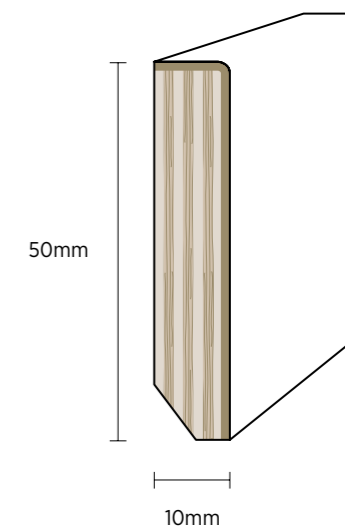







## Smussato

*Beveled*  
50x10mm



DETTAGLIO DI  
GIUNZIONE AD ANGOLO

### Essenze e Finiture / *Essence and Finishes*

		<b>DOUSSIÉ</b> DOUSSIÉ <b>Trasparente verniciato</b> <i>Transparent varnished</i>		<b>IROKO</b> IROKO <b>Trasparente verniciato</b> <i>Transparent varnished</i>
<b>ROVERE</b> OAK		<b>Grezzo</b> <i>Raw</i>		<b>Trasparente verniciato</b> <i>Transparent varnished</i>
		<b>Spazzolato grezzo</b> <i>Raw brushed</i>		<b>Spazzolato verniciato opaco</b> <i>Matte brushed varnished</i>
		<b>Effetto grezzo verniciato</b> <i>Raw effect varnished</i>		<b>Sbiancato verniciato</b> <i>Bleached varnished</i>
		<b>Tortora verniciato</b> <i>Tortora varnished</i>		
<b>TANGANICA</b> TANGANIKA		<b>Grezzo</b> <i>Raw</i>		<b>Tonalità noce medio verniciato</b> <i>Medium walnut-coloured varnished</i>
		<b>TEAK</b> TEAK <b>Trasparente verniciato</b> <i>Transparent varnished</i>		

### Laccati / *Lacquered*

<b>TANGANICA</b> TANGANIKA		<b>Laccato bianco traffico RAL 9016</b> <i>Traffic-white lacquered RAL 9016</i>		<b>Laccato grigio alluminio RAL 9006</b> <i>Grey aluminium lacquered RAL 9006</i>
		<b>Laccato bianco puro RAL 9010</b> <i>Pure white lacquered RAL 9010</i>		<b>RAL / NCS e colorazioni su richiesta</b> <i>RAL / NCS and colours on customer request</i>



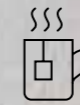

A volte serve un terzo colore per unire **sobrietà e matericità** in un insieme più caldo e confortevole.

*Sometimes a third color is needed to combine **sobriety and materic finishes** in a warmer and more comfortable ensemble.*

**Smussato**  
50x10mm





Basta un segno netto: un battiscopa o un profilo a parete per personalizzare un muro e **movimentare uno spazio a 360 gradi.**

*Just a clear sign: a baseboard or a wall profile to **customize a wall all around.***



## Smussato *Beveled* 120x13mm



DETTAGLIO DI GIUNZIONE AD ANGOLO

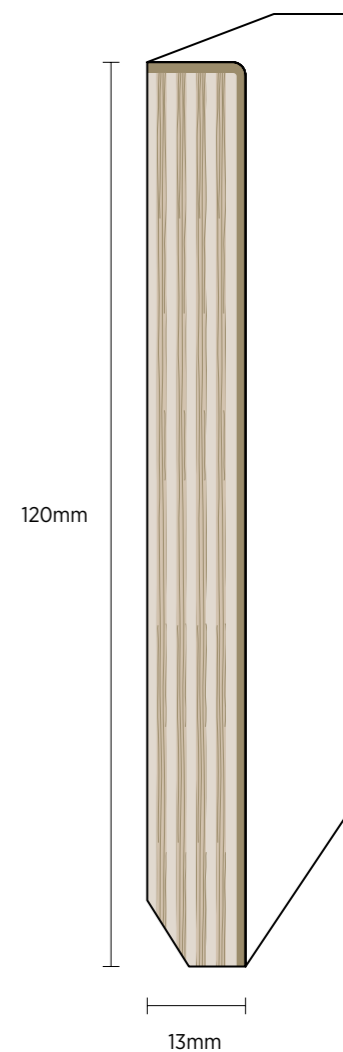

Smussato

### Essenze e Finiture / *Essence and Finishes*

**ROVERE**  
OAK



**Grezzo**  
*Raw*



**Trasparente verniciato**  
*Transparent varnished*



**TANGANICA**  
TANGANICA  
**Grezzo**  
*Raw*

### Laccati / *Lacquered*

**TANGANICA**  
TANGANICA

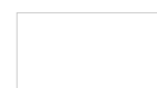

**Laccato bianco traffico RAL 9016**  
*Traffic-white lacquered RAL 9016*

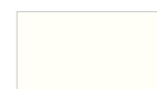

**Laccato bianco puro RAL 9010**  
*Pure white lacquered RAL 9010*



**RAL / NCS e colorazioni su richiesta**  
*RAL / NCS and colours on customer request*

Dallo scontro tra modernità e stile classico possono nascere **compromessi sorprendenti.**

*From the clash between modernity and classic style, **surprising compromises** can be born.*



**CIMABUE**  
**Massiccio sagomato**  
100x13mm

# Cimabue

100x13mm



DETTAGLIO DI GIUNZIONE AD ANGOLO

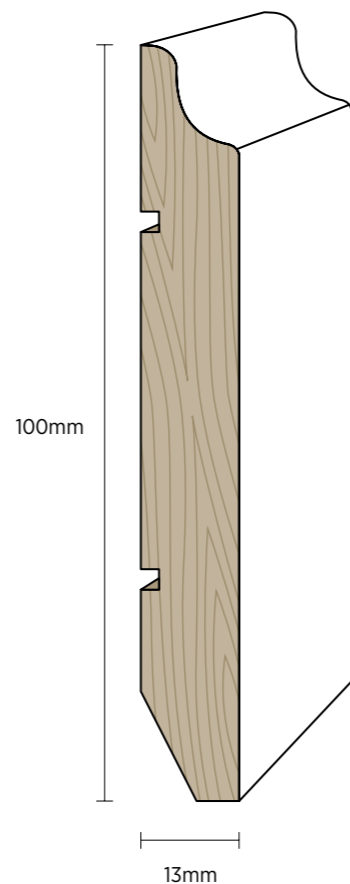

# Michelangelo

120x13mm



DETTAGLIO DI GIUNZIONE AD ANGOLO

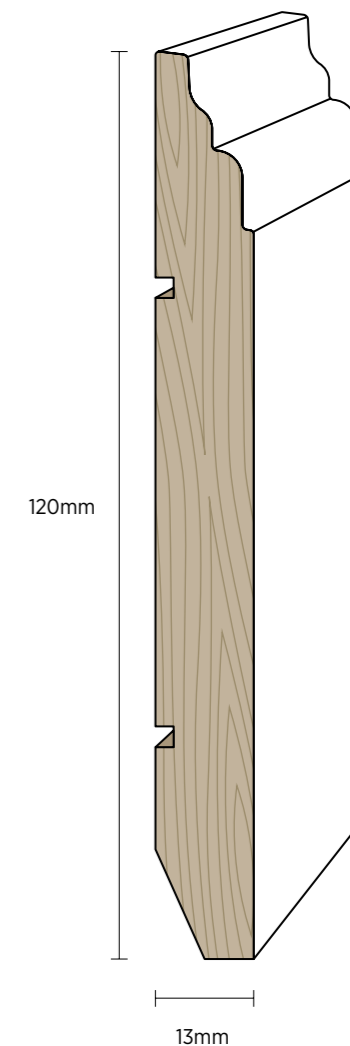

Massiccio sagomato

## Essenze, Finiture e Laccati / Essence, Finishes and Lacquered

AYOUS  
AYOUS



**Laccato bianco traffico RAL 9016\***  
Traffic-white lacquered RAL 9016\*



**Laccato bianco puro RAL 9010\***  
Pure white lacquered RAL 9010\*



**Grezzo**  
Raw



**RAL / NCS e colorazioni su richiesta**  
RAL / NCS and colours on customer request

\* Laccatura poro aperto / open pore lacquering

## Essenze, Finiture e Laccati / Essence, Finishes and Lacquered

AYOUS  
AYOUS



**Laccato bianco traffico RAL 9016\***  
Traffic-white lacquered RAL 9016\*

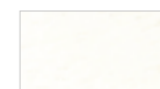

**Laccato bianco puro RAL 9010\***  
Pure white lacquered RAL 9010\*



**Grezzo**  
Raw



**RAL / NCS e colorazioni su richiesta**  
RAL / NCS and colours on customer request

\* Laccatura poro aperto / open pore lacquering



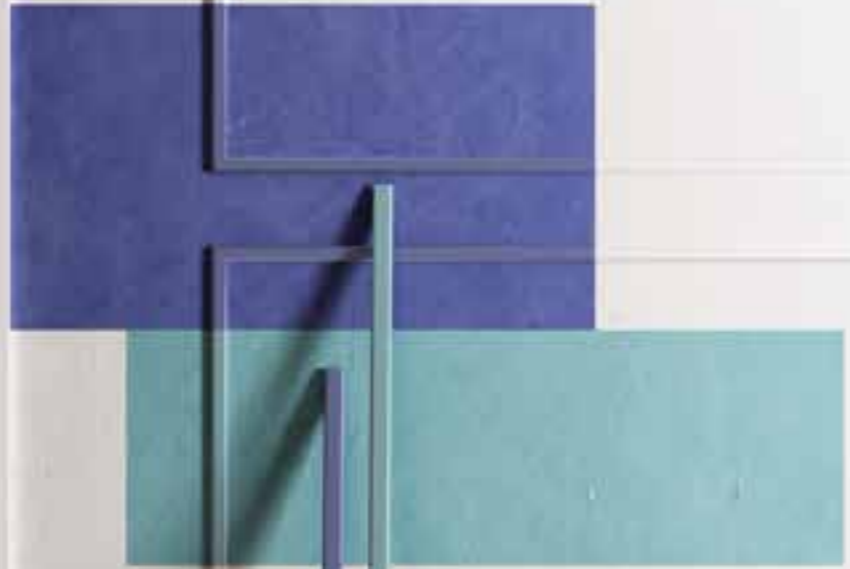

**Art. 045**  
**Asta da parati**  
22x6mm

Quando il colore incontra l'ombra di un profilo in rilievo, **la parete assume una dinamicità sempre nuova** man mano che il giorno avanza.

*When the color meets the shadow of a wall profile, **the wall takes on a new dynamism** as the day progresses.*

**MICHELANGELO**  
**Massiccio sagomato**  
120x13mm

Massiccio sagomato





Uno spazio bianco, arginato con eleganza, può dare risalto al tuo **arredo di design**, senza rinunciare al colore.

*A white space, elegantly embossed, can give prominence to your **design furniture**, without sacrificing color.*



**Art. 049**  
Asta da parati  
33x7mm



**DUCALE**  
Massiccio sagomato  
100x15mm



## Ducale

100x15mm

DETTAGLIO DELL'ASTA  
DA PARATI

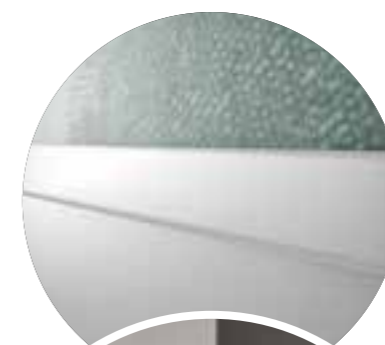

DETTAGLIO DI  
GIUNZIONE AD ANGOLO

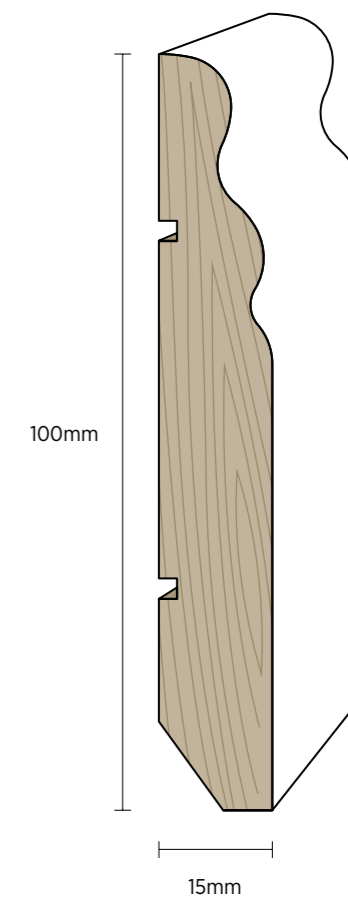

Massiccio sagomato

### Essenze, Finiture e Laccati / *Essence, Finishes and Lacquered*

**AYOUS**  
AYOUS



**Laccato bianco traffico RAL 9016\***  
*Traffic-white lacquered RAL 9016\**



**Laccato bianco puro RAL 9010\***  
*Pure white lacquered RAL 9010\**



**Grezzo**  
*Raw*



**RAL / NCS e colorazioni su richiesta**  
*RAL / NCS and colours on customer request*

\* Laccatura poro aperto / *open pore lacquering*

# Giotto

140/120x13mm



DETTAGLIO DI  
GIUNZIONE AD ANGOLO  
A SOFFITTO

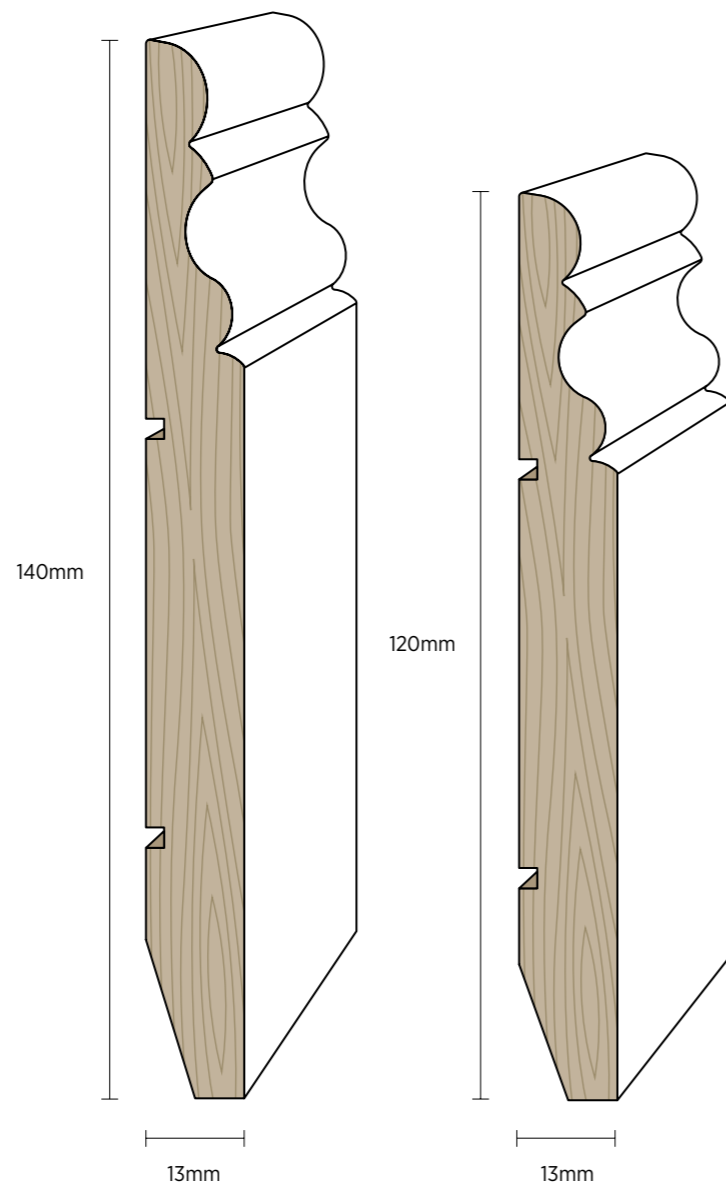

## Essenze, Finiture e Laccati / Essence, Finishes and Lacquered

AYOUS  
AYOUS

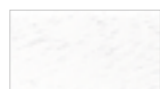

**Laccato bianco traffico RAL 9016\***  
Traffic-white lacquered RAL 9016\*

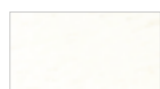

**Laccato bianco puro RAL 9010\***  
Pure white lacquered RAL 9010\*



**Grezzo**  
Raw



**RAL / NCS e colorazioni su richiesta**  
RAL / NCS and colours on customer request

\* Laccatura poro aperto / open pore lacquering



Incorniciare il soffitto con un profilo in tinta alza la stanza e crea **eleganti intermezzi tra alto e basso**.

Framing the ceiling with a matching profile raises the room and creates **elegant interlocks between top and bottom**.







**Un piccolo profilo è sufficiente a nascondere** la battuta del parquet e l'inizio di una piastrellatura importante.

**A small profile is enough to hide** the parquet ending and the beginning of an important tiling.

## Angolo a guscia

Shell

27x14mm

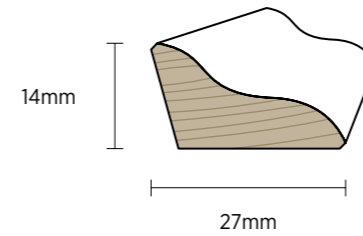

## Base

Base

12x8mm

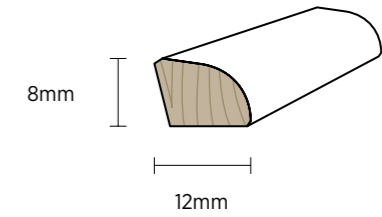

### Essenze e Finiture / Essence and Finishes

**ABETE**  
FIR



**Grezzo**  
Raw



**Trasparente verniciato**  
Transparent varnished

**LARICE**  
LARCH



**Grezzo**  
Raw



**Trasparente verniciato**  
Transparent varnished

**PINO**  
PINE



**Grezzo**  
Raw



**Trasparente verniciato**  
Transparent varnished



**Tonalità miele verniciato**  
Honey-coloured varnished

**AYOUS**  
AYOUS



**Tonalità noce chiaro verniciato**  
Light walnut-coloured varnished



**Tonalità noce medio verniciato**  
Medium walnut-coloured varnished



**Tonalità rovere verniciato**  
Oak-coloured varnished

**ROVERE**  
OAK



**Grezzo**  
Raw



**Trasparente verniciato**  
Transparent varnished

### Laccati / Lacquered

**AYOUS**  
AYOUS



**Laccato bianco traffico RAL 9016\***  
Traffic-white lacquered RAL 9016\*

### Essenze e Finiture / Essence and Finishes

**LEGNO DURO / AYOUS**  
HARDWOOD / AYOUS



**Tonalità mogano verniciato**  
Mahogany-coloured varnished



**Tonalità noce chiaro verniciato**  
Light walnut-coloured varnished



**Tonalità noce medio verniciato**  
Medium walnut-coloured varnished



**Tonalità rovere verniciato**  
Oak-coloured varnished

**FAGGIO**  
BEECH



**Trasparente verniciato**  
Transparent varnished

**ROVERE**  
OAK



**Grezzo**  
Raw



**Trasparente verniciato**  
Transparent varnished

### Laccati / Lacquered

**LEGNO DURO / AYOUS**  
HARDWOOD / AYOUS



**Laccato bianco traffico RAL 9016**  
Traffic-white lacquered RAL 9016



**Laccato bianco puro RAL 9010**  
Pure white lacquered RAL 9010

\* Laccatura poro aperto / open pore lacquering

## Chiusura e raccordo del battiscopa

*Baseboard closing and junction*



Il taglio a 45° è la scelta ideale per chiudere un battiscopa dal profilo scoperto.

*The 45° cut is the ideal choice to close a baseboard with an open profile.*



Tagliare a 45° i battiscopa permette di seguire il profilo di uno stipite o di una scala in maniera continua e uniforme, senza esporre il profilo in legno.

*Cutting the baseboard at 45° allows to follow a jamb casing or the steps of a stair in a continuous and uniform manner, without exposing the wooden section of the profile.*



## Design “di contorno”

Battiscopa in legno  
*Wooden baseboards*

**I colori e le tonalità dei campioni nonché le illustrazioni presentate in questo catalogo, sono puramente indicative e non vincolanti.**

Le tonalità RAL indicate sono da ritenersi vincolanti solo se comparate con una tabella RAL e NCS ufficiale che farà da riferimento per la produzione del profilo. In ogni caso onde evitare controversie sulla correttezza della tonalità è sempre necessario, nel caso in cui il profilo debba essere accostato ad altri elementi in tinta RAL e NCS, stabilire anticipatamente un campione che farà da riferimento per la compatibilità del colore.

**The colors and hues of the samples, and the illustrations show into this catalog, are merely indicative and are non-binding.**

The RAL colour shades are only binding if compared with an official RAL and NCS chart which will provide the benchmark for production of the profile. In all other cases, to avoid disputes concerning colour shades, in the event that the profile has to be matched with other items produced to RAL and NCS colours, a colour benchmark sample must be agreed in advance to ensure colour compatibility.

### **CREDITS**

**AD:** NEIKO SRL

**VIRTUAL IMAGES:** NEIKO SRL

**PRINT:** GRAFICHE ANTIGA

### **CONTATTI**

**SAN GIUSEPPE SRL**

Via Cal de Livera, 113/B  
31029 Vittorio Veneto (TV)

**TEL:** +39 0438 50 16 43

**EMAIL:** info@sangiuseppesrl.com





Via Cal de Livera 113/B  
31029 Vittorio Veneto (TV) Italia  
Tel. +39 0438 501643 - Fax +39 0438 501570  
[info@sangiuseppesrl.com](mailto:info@sangiuseppesrl.com)  
[www.sangiuseppesrl.com](http://www.sangiuseppesrl.com)